

Structural drilling using the high-frequency (sonic) rotary method

Strukturno vrtanje z uporabo visokofrekvenčne (sonic) rotacijske metode

Jurij Šporin*, Željko Vukelić

Faculty of Natural Sciences and Engineering, Department of Geotechnology, Mining and Environment, Slovenia

*E-mail: jurij.sporin@ntf.uni-lj.si

Abstract

In Slovenia, there is widespread use of structural drilling along with classical core drilling. Recently, however, the need has arisen for a highly effective core drilling method with the aid of which high-quality core might be obtained. In order to achieve this aim, one among several Slovenian companies dealing with geological surveying has decided to implement structural drilling using a high-frequency drilling method. The following article presents the theoretical foundations for such a high-frequency method, as well as the manner of its implementation. In the final part of the article, a practical comparison between the conventional and the high-frequency core drilling methods is also provided.

Key words: structural drilling, high-frequency method, core drilling, sonic drilling

Izvleček

Uporaba strukturnega vrtanja z uporabo klasičnega jedrovanja je v Sloveniji zelo razširjena. V zadnjem času pa se je pojavila potreba po visoko učinkoviti metodi jedrovanja s katero lahko pridobimo kvalitetno jedro. Za uresničitev tega se je eno izmed Slovenskih podjetij, ki se ukvarja z geološkimi raziskavami odločilo za izvajanje strukturnega vrtanja z uporabo visokofrekvenčne metode.

V članku so prikazane teoretične osnove delovanja visokofrekvenčne metode in način njenega izvajanja. V zadnjem delu članka pa smo se posvetili praktični primerjavi med klasično in visokofrekvenčno metodo jedrovanja.

Ključne besede: strukturno vrtanje, visokofrekvenčna metoda, jedrovanje

Introduction

In Slovenia, until recently, classical methods of structural drilling, founded on the principles of core drilling along with rotational methods, have been used. The former have utilised the principle of progression into soils and rocks through the creation of vertical axial loads on their drill bits, as well as through the use of varying drill bits, each of which has been adapted to the specific kind of material through which the drilling is to be carried out. This method of drilling has led to the lagging behind of structural drilling relative to more contemporary methods, which allow for the acquisition of high-quality core at higher penetration rate with lower consumption of energy.

This article demonstrates the recent, gradual introduction of contemporary technology pertaining to structural drilling using the high-frequency rotational method, i.e. sonic drilling, in Slovenia. The aforementioned method is founded on the creation of high-frequency vibrations at low revolutions of the rotary head. The high frequency of vibrations creates local fracturing of material through which the drilling progresses. The progressions concurrent with the implementation of drilling using the former method are achieved up to five times faster than those using already established, classical methods of structural drilling.

Brief History of the Development of the High-Frequency Rotational Method of Structural Drilling

The first reflections on and research pertaining to the possibilities of employing high-frequency methods date back almost 100 years, when the Romanian engineer George Constantinesco wrote a treatise for the British Admiralty, which he entitled the Theory of Sonics. In May 1918, the British Admiralty established a development plant, as part of which devices based on Constantinesco's specifications were manufactured. However, after the conclusion of World War I, this research ceased.

In 1930, another Romanian engineer, Ion Basgan, introduced the high-frequency method to a conventional drilling rig. The result of Basgan's attempts was an increase in daily drilling progressions. Until 1970, further develop-

ment mostly took place only in the theoretical sense, with a modest number of experiments being conducted and an equally modest number of prototype drilling devices being made. It is only the year 1985 that is marked as the beginning of the use of high-frequency rotational methods in engineering practice.

The Principle of Operation of the High-Frequency Rotational Method of Structural Drilling

The high-frequency drilling system consists of three primary components, namely, a high-frequency drill head, drill rods along with drill bit and a formation through which the drilling may be carried out. All three components of the system must be harmonised in order to ensure the effectiveness of the method.

The drill head, with the aid of which a high-frequency wave is created, is an advanced hydraulically powered system. The eccentrics installed inside the drill head generate a high-frequency sinusoidal wave, i.e. sinusoidal vibration, which is then transferred through the drill rods and core barrel to the drill bit [1–4].

Through the creation of vertically oriented, mechanically induced pressure waves, a load in the range from 22,000 kg to 127,000 kg at frequencies of up to 150 Hz may be generated [1–4].

A model of a high-frequency drill head is displayed in Figure 1.

In order to achieve the maximum drilling effect using the high frequencies of vertical movement that are created in the drill head, an effective transfer of such frequencies, with minimal energy loss, to the drill bit or the material through which drilling is carried out is required. The transmission of movement is carried out via the drill rods.

The purpose of the high-frequency drill head is to provide as much energy as possible, which is transmitted from the drill rods to the drill bit with the least possible amount of energy loss.

In wave theory, we distinguish between points with maximum movement and corresponding velocity, i.e. the crests of a wave, and points with minimum movement and corresponding position, i.e. the nodes of a wave. The locations of the crests and nodes are dependent on the length of the drill rods, their physical characteristics and the frequency of their vibrations [2].

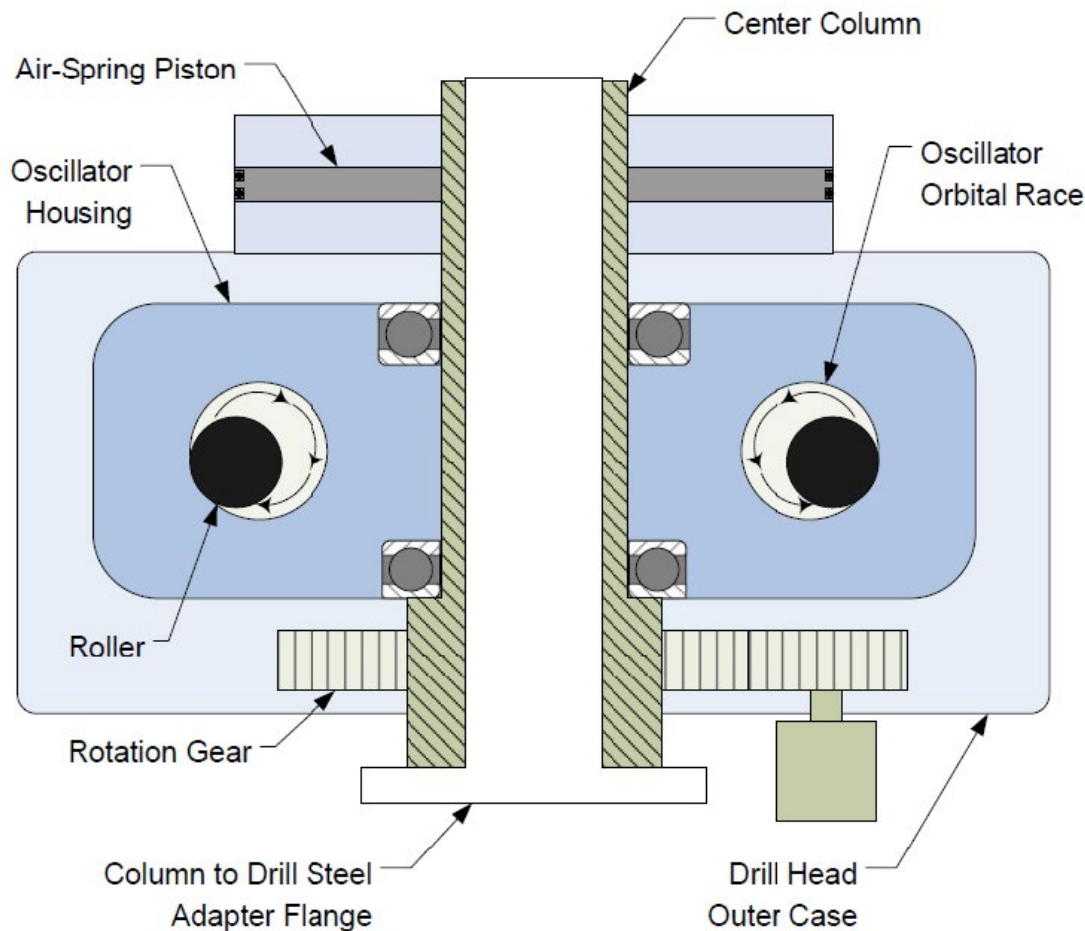

Figure 1: A diagram of a high-frequency drill head (source: Resodyn Corporation).

The basic resonance frequency in the axial direction of any given length of the drill rods is obtained using the expression:

$$f = \frac{c}{2l} \quad (1)$$

where the elements are denoted as follows:

f – the frequency at the occurrence of resonance [in Hertz, Hz]

c – the speed of sound through the material of the drill rods [in metres per second, m/s]

l – the length of the drill rods [in metres, m]

The above equation makes it evident that, along with the progression of drilling, and thus the extension of the length of the drill rods, it is necessary to decrease the frequency required in order for the drill rods to achieve resonance. As a result, as the drill rods are extended, the force that is generated by the drill head at the

same frequency is reduced. The drill rods are no longer in a state of resonance. Therefore, with an increase in depth, it is necessary to add multiples of the fundamental frequency in order to maintain the wave crests close to the top or bottom line of the drill rods and thereby facilitate depth progression.

When the vibration generated at the high-frequency drill head is aligned with the resonance in the drill rods along with the drill bit, the result is a “liquefying” of material that surrounds the drill rods. This causes a reduction in the force of friction around the drill rods [2].

The drill bit at the bottom of the borehole does not carry out the cutting of the material, as is to be expected from classical rotational methods, but instead pulsates when it comes into contact with the material. As a consequence of such pulsating, the material through which the drill-

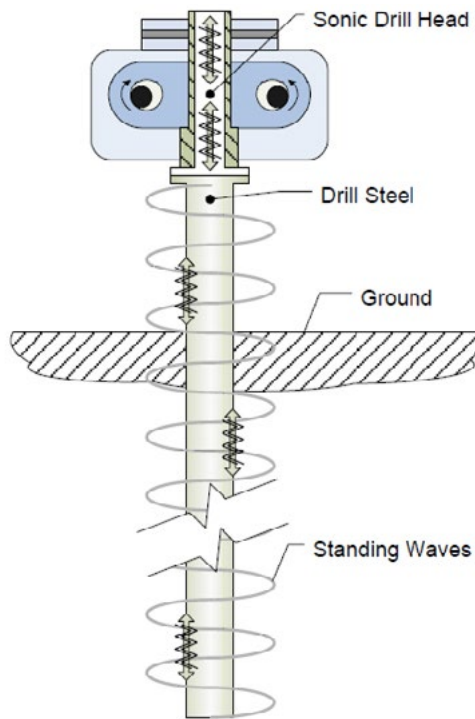

Figure 2: The operational principle of high-frequency drilling (source: Resodyn Corporation).

ing is performed either crumbles, as in the case of drilling through rocks, or is pushed out, as in the case of drilling through soils [5–7].

Due to this mode of action on the material through which the drilling is conducted, there is no need for a high number of revolutions of the drill bit. Normally, the number of revolutions ranges up to 150 rpm. In the event that the drill rods do not rotate, the gears on the drill bit, which transmit energy to the material through which the drilling is conducted, will continue encountering the same spot, which will result in a reduction in the speed of progression [2]. The principles of such drilling are demonstrated in Figure 2.

In the classical method of core drilling, the drill bit constitutes one of the essential elements for achieving progress, whereas this is not the case in high-frequency drilling. In the case of the latter, the shape of the drill bit, the distribution of inserts, the material matrix and the shape of the flushing channels all have no decisive influence on the progress of the drilling. In such a case, the optimisation of the drill bit mainly relates

to the durability of the material making up the bits and, to a lesser extent, to their shape and distribution.

In such a case, a greater influence on the rate of progression is determined by the efficiency of the transfer of energy from the drill head to the drill bit. The load on the drill bit has a greater importance in classical rotational drilling [5–7], as the load on the bit creates the conditions that lead to the fragmentation of the material that is being drilled through.

If the matter is greatly simplified, the high-frequency drilling method can be taken as similar to the percussion rotational method [8, 9] and, on the basis of such an assumption, calculation of the power that “beats down” on the material through which the drilling is carried out can be made as follows [2].

Calculation of the Power Required for the Implementation of Drilling Operations

The high-frequency core drilling method is similar to the classic rotational core drilling method. This is why, when calculating power, it is possible to start from generally accepted equations used in the calculations of power involved in classic rotational core drilling [2, 5, 10].

The forces for grinding material on the surface of the drilling bit are given by the following equations [10]:

$$ds = \rho \cdot d\theta \cdot dr \quad (2)$$

$$T = \lambda \cdot q \cdot \rho \cdot d\theta \cdot dr = \lambda \cdot q \cdot ds \quad (3)$$

where the elements are denoted as follows:

T – the force of the grinding of the material [in newtons, N]

λ – the coefficient of friction between the material and the drill bit

q – the load on the material [in newtons per square metre, N/m²]

r – the path at dQ [in metres, m]

dQ – the micro-revolution during the “beating down” [in degrees, °]

dr – the inner diameter of the micro-part of the drill bit [in metres, m]

ds – the micro-area [in square metres, m²]

r – the inner diameter of the drill bit [in metres, m]

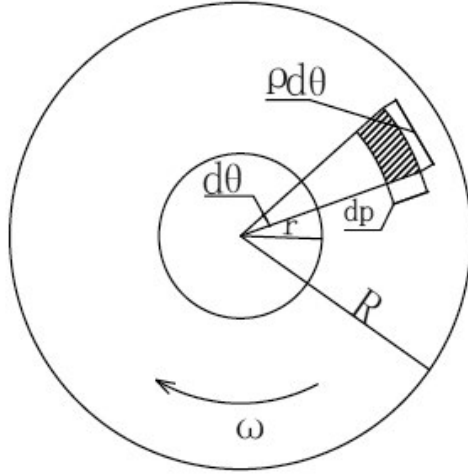

Figure 3: A diagram of a cross-section of the drill bit.

The torque M , which is generated by the load T on a micro-area, is given by the following equation [10]:

$$dM = T \cdot \rho = \lambda \cdot q \cdot \rho^2 \cdot d\theta \cdot dr \quad (4)$$

where

$$q = \frac{P}{S} \quad (5)$$

with P – the force on the drill bit in the axial direction [in newtons, N]

S – the surface area of the drill bit [in square metres, m^2]

and

$$S = \pi \cdot (R^2 - r^2) \quad (6)$$

with R – the outer diameter of the drill bit [in metres, m]

Therefore, the torque for the entire drill bit is represented as follows [10]:

$$M = \frac{2\lambda \cdot P \cdot (R^2 + R \cdot r + r^2)}{3(R + r)} \quad (7)$$

The power N , needed in order to act upon the material, amounts to the following [10]:

$$N = M \cdot \omega = \frac{2\pi \cdot n \cdot \lambda \cdot P \cdot (R^2 + R \cdot r + r^2)}{3(R + r) \cdot t} \quad (8)$$

where

ω – angular speed [in per second, s^{-1}]

$$\omega = \frac{2\pi \cdot n}{t} \quad (9)$$

n – the number of revolutions of the drill head – drill rods

t – time [in seconds, s]

Considering the fact that the high-frequency rotational method has been simplified as equivalent to the impact rotational method, the energy of the impact W may be calculated using the following equation [10]:

$$W = \frac{F^2 \cdot t^2}{2 \cdot m} \quad (10)$$

where

F – the force of the impact of the drill bit on the material being drilled through [in newtons, N]

t – the duration of impact [in seconds, s]

m – the mass of the drill rods and the bit inside the borehole [in kilograms, kg]

The power of the high-frequency drill head at a known frequency is therefore given by the following equation [10]:

$$N = W \cdot f = \frac{F^2 \cdot t^2 \cdot f}{2 \cdot m} \quad (11)$$

where

f – the frequency of vibrations [in hertz, Hz]

In the case of drilling using a high-frequency drill head, use of an excessive load leads to a situation whereby the drill bit can no longer move and act on the material through which the drilling is being conducted. When this occurs, we may talk of the formation of a knot at the site of drilling bit, leading to reduced progress. Such a situation may lead to the fracturing of the drill rods due to the influence of the vibrations upon them.

Use of Mud During High-Frequency Core Drilling

In the case of most materials upon which the high-frequency core drilling method is applied, the use of flushing water is not required. However, in cases in which, due to the removal of de-

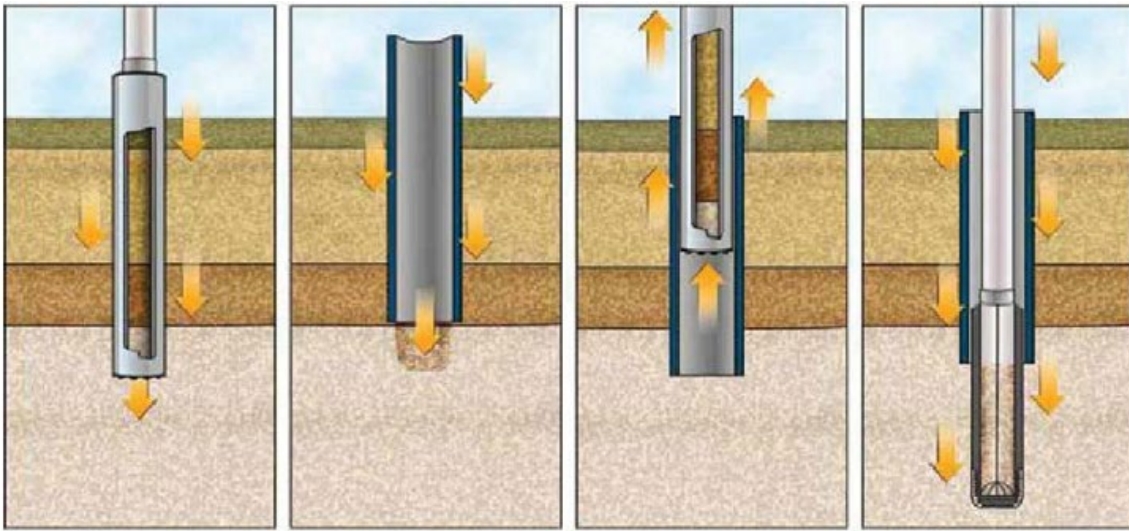

Figure 4: The process of core drilling using the high-frequency method.

bris, this is necessary, regular water is usually sufficient. In these cases, there is a lower consumption of flushing water than in core drilling, which uses the classical rotational method [6, 10].

The Process of Core Drilling Using the High-Frequency Method

The process of core drilling using a high-frequency method is similar to classical methods of core drilling [11, 12]. In essence, it is carried out in three phases, as follows:

Phase I: Core drilling

Phase II: Drilling around the core barrel with protective casing

Phase III: Removal of the core from the borehole along with removal of the core from the core barrel

In phase I, the core barrel is advanced to the soil. Soil material is collected into the core barrel. Phase II is intended to secure the well stability, with override core barrel with sonic casing, so that the core barrel can be removed from the well in phase III. These three phases are periodically repeated in this sequence until the final drilling depth is achieved. This method is usually used in soil materials, such as gravels, sands, soft clays, etc., because the open borehole is unstable during the core barrel extraction manoeuvre and the borehole may collapse.

The process of core drilling is represented in Figure 4.

In rock materials where there is no danger of borehole collapse, the drilling operation is simplified to drilling with core barrel.

Use of the High-Frequency Core Drilling Method in Slovenia

The high-frequency core drilling method is still in its infancy in Slovenia, as there is currently only one drilling rig equipped for it in the country. The reason for the poor representation of such technology may be attributed to the high costs of the rig and the equipment for it, as well as the modest availability of spare parts and the current lack of projects as part of which structural core drilling might be implemented [13–15].

The research part of our work was carried out on the construction site of HE Brežice, Slovenia, where we were able to practically verify and measure the parameters necessary for the successful implementation of such core drilling. In the area where the works were carried out, there were several drilling rigs involved in structural drilling. One of the rigs was equipped with a high-frequency drill head, while others implemented classic rotational core drilling. For this reason, all structural boreholes were created under the same conditions and we were provided with an excellent testing ground for the purposes of comparing technologies.



Figure 5. Drilling equipment fitted with a high-frequency drill head (source: Gecko Ltd.).



Figure 6. Core obtained through the use of high-frequency core drilling (source: Gecko Ltd.).

Table 1 The laboratory tests conducted on samples (source: Gecko Ltd.).

	Material	Volumetric weight of dry material, γ	Uniaxial compressive strength	Uniaxial tensile strength	Elasticity modulus E	Poisson's ratio n
			Cylinder	Cylinder		
		kN/m^3	σ_c MPa	σ_t MPa	MPa	-
1	Limestone	26.2	35.2	2.9	-	-
2	Marlstone breccia	25.4	17.2	-	-	-
3	Breccia with marlstone	25.2	24.6	3.9	3340.0	0.04
4	Marly dolomite	26.5	31.6	5.4	59750.0	0.36
5	Limestone breccia	26.0	37.7	2.7	-	-
6	Dolomite marlstone breccia	25.0	31.9	2.4	49063.0	0.44
7	Dolomite breccia	26.5	30.4	4.8	-	-
8	Dolomite breccia	26.5	40.1	8.9	48940.0	0.10
9	Dolomite	27.1	16.1	-	-	-
10	Dolomite breccia	26.1	32.7	5.4	-	-
11	Dolomite breccia	26.9	61.7	5.9	-	-
12	Dolomite breccia	25.0	27.1	-	-	-
13	Dolomite breccia	24.1	73.7	4.5	-	-
14	Dolomitised limestone	27.1	65.3	5.1	-	-
15	Breccia dolomite	27.3	89.5	5.2	56780.0	0.20
16	Breccia dolomite	26.8	94.3	5.0	-	-
17	Dolomitised limestone	26.8	56.4	9.1	-	-
18	Dolomite breccia	27.0	96.0	6.7	-	-
19	Dolomite breccia	26.2	102.9	7.2	66920.0	0.18
20	Brecciated dolomitised limestone	27.0	29.9	-	-	-
21	Limestone with shale intercalations	26.0	27.8	3.2	19675.0	0.10
22	Limestone	26.3	59.4	6.2	-	-
23	Limestone	26.5	91.7	7.8	-	-
24	Limestone	26.4	65.8	8.0	-	-

Conclusion

At the beginning of the year 2016, high-frequency core drilling technology was implemented for the first time in Slovenia. The technology was used at the time in order to obtain structural boreholes that enabled the verification of the geological composition of the area containing the accumulation basin of the future HE Brežice.

To facilitate a comparison between the classic and the high-frequency core drilling methods, a number of different drilling rigs that implemented the classic method and one drilling rig equipped with a high-frequency drill head were made available. A comparison between the two methods was performed in accordance with the measured rate of progression as well as the quality and quantity of the harvested core.

Structural drilling was carried out through the layers of silt, clayey gravel, gravel and conglomerate. The equipment used in the application of both drilling methods, in order to compare the listed parameters, was a single-walled corer.

As part of the introduction of high-frequency technology in Slovenia, the following advantages were identified: large progressions in comparison to those achieved using classical core drilling technology as well as a high quality and quantity of the harvested core.

The progressions achieved using high-frequency core drilling were up to four times higher than those achieved using classical core drilling methods. The core obtained using the high-frequency method was also superior to the core obtained using the classical methods along with a single-walled corer. The core obtained using the high-frequency method was more compact and there was no secondary fragmentation in the corer, nor was there mixing and segregation of the core within the corer. In the core obtained using the high-frequency method, layers of harder formations (e.g. conglomerate) were clearly visible immediately following extraction, while in the core obtained using the single-walled corer, these were not immediately noticeable. Instead, they could be observed only after careful review and surveying of the core, although there was no way to precisely determine the thickness of the layers.

Considering all of these advantages, we consider the choice to implement core drilling using the high-frequency, rather than the classical, method to be professionally and economically justified, as it has proven itself to be an excellent method in terms of providing good progressions as well as a high quality of acquired core.

References

- [1] Yu Wang, Baolin Liu, Qin Zhou, Yunabiao Hu, Guomin Li (2013): Design of a Sonic Drill Based on Virtual Prototype Technology, *Transactions of the Canadian Society for Mechanical Engineering*, Vol. 37, No. 2, pp. 185 - 196
- [2] Lucon P.A. (2013), *Resonance: The Science Behind the Art of Sonic Drilling*, Dissertation, Montana State University 2013; pp. 224
- [3] Bar-Cohen Y., Sherrit S., Dolgin B., Pal D., Peterson T., Kroh J., Krahe R. (2001): Ultrasonic/Sonic Drilling/ Coring (USDC) for In Situ Planetary Applications, *Annual International Symposium on Smart Structures and Materials*, Paper No. 4327-55, pp. 8
- [4] Yu Wang, Qin Zhou, Baolin Liu, Zhijun Li, Mingxin Huang (2015): Design and model analysis of the sonic vibration head, *Journal of Vibroengineering*, Vol. 7, Issue 5, pp. 2121 – 2131
- [5] Šporin J., Vukelić Ž. (2007): Optimization of geo-mechanical-structural drilling with diamond crowns, *RMZ M&G*, Vol. 54, No. 1, pp.117 – 126
- [6] Shuter E., Teasdale W.E. (1989): *Techniques of water-resurce investigations of the United States geological survey, Application of drilling, coring and sampling techniques to test holes and wells*, U.S. department of the interior, Book 2, pp. 106
- [7] Sterling S., Briscoe G., Melany M. (2011): *Drilling, logging and sampling of DGR-5 and DGR-6*, Geofirma, DGR Site characterization document, Document id.: TR-09-01, pp. 175
- [8] Sapinska-Sliwa A., Wisniowski R., Korzec M., Gajdosz A., Sliwa T. (2015): *Rotary – percussion drilling method – historical review and current possibilities of application*, AGH University of science and Technology, Faculty of drilling, oil and gas, Vol. 32, No. 2, pp. 313 – 323
- [9] Han G., Bruno M., Dusseault M.B. (2005): Dynamically Modelling Rock Failure in Percussion Drilling, *Alaska Rocks 2005, The 40th U.S. Symposium on Rock Mechanics (USRMS): Rock Mechanics for Energy, Mineral and*

- Infrastructure Development in the Northern Regions, held in Anchorage, 05-819, pp. 7*
- [10] Li Lianggang, Zhang Bing, Luo Qiang (2014): Study on Vibration Frequency and Rock Fragmentation Effect of Sonic Drill Rig, *Geological Engineering Drilling Technology Conference*
- [11] Bratton Steve (2012): Sonic Drilling in Support of Geotechnical Investigation and Geo-Construction, *Geo-Strata*, pp. 24 – 31
- [12] Wentz F.J., Dickenson S.E. (2013): Pore pressure response during high frequency sonic drilling and SPT sampling in liquefiable sand, *19th NZGS Geotechnical Symposium*, pp. 9
- [13] Campbell J. (2016): Versatility and Other Benefits Help Drive Adoption of Sonic Drilling, *National driller*, May issue, pp. 3
- [14] Weikel E.O. (2014): Geotechnical drilling and sampling in earth embankment dams and levees, *US Army Corps of Engineers, Regulation No. 1110-1-1807*, pp.16
- [15] Davis J.P. (2005): Sensitive Infrastructure Sites - Sonic Drilling Offers Quality Control and Non-Destructive Advantages to Geotechnical Construction Drilling, *Boart Longyear*, pp.14