

## Image Processing for Technological Diagnostics of Metallurgical Facilities

*Lyubka Doukovska<sup>1</sup>, Venko Petkov<sup>2</sup>, Emil Mihailov<sup>2</sup>, Svetla Vassileva<sup>3</sup>*

<sup>1</sup>*Institute of Information and Communication Technologies, 1113 Sofia*

<sup>2</sup>*University of Chemical Technology and Metallurgy, 1756 Sofia*

<sup>3</sup>*Institute of System Engineering and Robotics, 1113 Sofia*

*Emails: doukovska@iit.bas.bg    venko@uctm.edu    emil@uctm.edu    si27v06@gmail.com*

**Abstract:** *The paper presents an overview of the image-processing techniques. The set of basic theoretical instruments includes methods of mathematical analysis, linear algebra, probability theory and mathematical statistics, theory of digital processing of one-dimensional and multidimensional signals, wavelet-transforms and theory of information. This paper describes a methodology that aims to detect and diagnose faults, using thermographs approaches for the digital image processing technique.*

**Keywords:** *Technological diagnostics, digital image processing, predictive maintenance, fault detection.*

### 1. Introduction

The object for image registration is considered a source of energy as a result of its own emission or reflection. The corresponding to this energy image is called input or not distorted. The object energy is transformed into another type that is more convenient for registration: an energy transferring the image which is transformed by the registration device into a registered image. The obtained image is called output or observed image. During the process of forming the image, it is changed by the noise that is accepted to be treated as additive to the registered image. The forms for registration of the image are quite different in fact. The traditional form of

registration is the photo-chemical – the photography. The registration may also be performed in an analog form via its transformation into a one-dimensional signal by the respective scan. Digital registration of the image is obtained via discretization of the image (transformation of a one-dimensional signal and operating with discrete points) followed by quantization of its level by an Analog-Digital Converter (ADC). Different techniques are analyzed using intelligent approaches to fault diagnosis. Results from application of passive and active thermography are presented. Active thermography is acknowledged as one of the most powerful tools for nondestructive control to localize cracks and defects in depth like metals, composite materials and polymers.

## 2. Digital images processing

The process of image formation includes a transition from three-dimensional objects to their images in the form of two-dimensional scalar fields which can be mathematically described by two-dimensional functions [1]. The obtained images may be treated as a two-dimensional signal (deterministic or random) that carries information about the object.

The main directions in digital processing according to [2] can be formulated as the following ones:

1. Effective compression of video information. This direction was the first one historically and it is related to the transfer of information along the connection channels [3]. Fig. 1 shows a sample scheme of the compression algorithm.

2. Improving the qualities and restoration of images. Though this direction originated also for image transmissions, it is basically related to correcting distortions of input converters. The object correction includes frequencies (colour) characteristics of converters (their spatial resolution), spectral (colour) characteristics, geometrical deformations or specific deformations like focusing or blurring due to motion [4]. There are significant successes due to using a formalized mathematical apparatus based on methods for linear or nonlinear filtration. A significant share in this direction belongs to the application of spectral methods for processing [5].

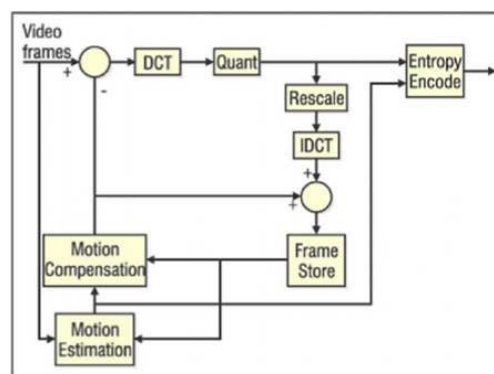

Fig. 1. The block scheme of the compression algorithm

3. Image analysis – it includes a large number of problems. Its main goal is the separation of significant for the specific application features. Optical Character Recognition (OCR) of numbers, letters and special symbols; cells in medicine; details in robotics; terrain objects for cosmic or aircraft images belong to it. Another more sophisticated class of problems covers the analysis of scenes for robotics, the landscape interpretation or the analysis of landscape forms and artificial facilities for remote research and digital photogrammetry. While the first class of problems results in significant successes, the second one confronts with certain difficulties, especially for analysis of higher levels and it is connected with the development of methods for automatic (machine) understanding based on the accumulated knowledge; it is a typical problem of Artificial Intelligence (AI) [6].

4. Image synthesis. This direction includes image restorations based on their coding (machine graphics problems) or image restorations based on their projections (in photogrammetrical processing of stereo images or in digital tomography [7]).

5. Organization of storage or search of images. The solution of these problems is related to the construction of data bases of images. This problem is of extreme importance for images from cosmic information devices of video information and also for automatic processing of documents with text and also with multilevel graphical images. The solution of this problem requires besides the usage of adequate technical tools and methods for data storage also efficient methods and algorithms for compression of visual information (one-dimensional and two-dimensional).

### 3. Information processing methods

According to the way of conversion of the information from the object, methods for processing can be parallel and sequential. Sequential methods are more related to solving problems for image analysis. Parallel processing may be performed in an optical or digital form. Sequential processing is done digitally in usual cases. Parallel processing is more related to identical operations for the whole image, for corrections of the obtained images, their compression or for feature selections from them. The main advantage of parallel processing is the higher rate of forming the final results. The advantage of sequential processing is the enhanced fixation of links between separate parts of the image and the formation of complex hierarchical descriptions that are difficult for realization with parallel processing.

The basic procedural stages are identical regardless of the problematic domain. They may be generalized in the following block diagram:

1. Input of the image and its preprocessing to correct distortions from the input converters.

2. Information reduction to obtain a compressed representation only with features that are substantial for a given class of problems: structural information representation.

3. Retrieval of specific data necessary to solve a concrete problem: identification of objects or an estimate of their parameters.

The specialization of the generalized graph of transforming visual information for solving specific problems of digital photogrammetry is of particular interest. It is presented in Fig. 2.

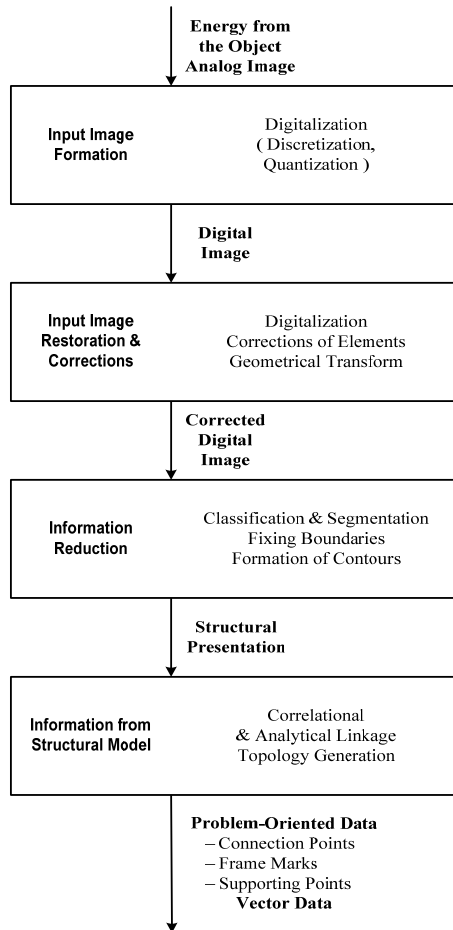

Fig. 2. Basic stages of procedural images processing

The analysis of this block diagram depicts the relative independence of the first stage on the character of the processed information. The second stage is the most significant one from point of view of image processing. Its specific realization depends on the final goal for the image transformation. The third stage comprises retrieval of the useful information that is specific for the solved problem.

#### 4. Image processing examples for technological diagnostics

Diagnosis of an induction motor stator fault is presented in [8]. Induction motors are the most widely used electrical machines. These motors play a very important role in the present industrial life. Therefore, the need to ensure a continuous and

safety operation for this motors, involves preventive maintenance programs with fault detection techniques. In general, condition monitoring schemes have concentrated on sensing specific failure modes. In the last years the monitoring of induction motors becomes very important in order to reduce maintenance costs and prevent unscheduled downtimes.

New procedures proposed for the detection of a three-phase induction motor stator fault can be found in [8]. These procedures are based on the image identification of the stator current Concordia patterns, and will allow the identification of turn faults in the stator winding, as well as its correspondent severity. The identification of the faulty phase is another important feature of the proposed algorithm.

In order to implement pattern recognition based fault detection, a feature-based recognition of the current stator pattern, independent of their shape, size and orientation must be obtained. Finding efficient invariant features is the key to solve this problem. Particular attention is paid to statistic moments and visual-based features obtained in the image processing system. The proposed image-processing algorithm is divided into three stages: image composition, boundary representation and feature extraction (Fig. 3).

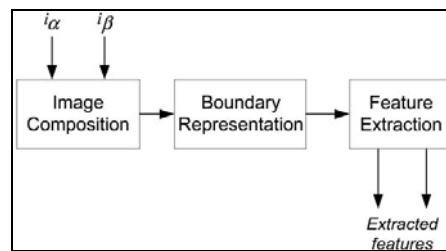

Fig. 3. Structure of the image processing based system

The inputs for the image processing based system are the  $\alpha\beta$  stator currents. The feature extraction must identify the image characteristics that can be obtained from the image composition. It was possible to verify that the obtained images for a correct or a faulty motor are different. These differences are obtained by the feature extraction block.

The system presented in [8] is based on the obtained stator currents and the correspondent Clark-Concordia transformation. This results in a circular or an elliptic pattern, of the Clark-Concordia stator currents. From the obtained current patterns an image processing algorithm was used to identify if there is a motor fault.

In paper [9] the result is contradicting with physiological mechanisms of vision and a new computation model is proposed to simulate two important mechanisms of vision which are visual cortex receptive field topology construct and synchronous oscillation among a neuron group. To solve the problem of trained image fault detection, a novel algorithm was proposed based on the above computation model. The experiment results show that the algorithm can increase the ault detection rate effectively compared to traditional methods which are absent in the above two important mechanisms of vision.

Based on the model of visual perception, a CBIFD (Content-Based Image Fault area Detection) algorithm is proposed in [9] for image fault area detection. The new algorithm is motivated as follows: First, learn neurons receptive fields from the image sequence of the train. Then calculate the neural response of normal image and fault image, and use Pulse Coupled Neural Network (PCNN) to filter the response coefficients for finding out the best neural response. Finally, output its corresponding content for fault detection. Fig. 4 shows the flowchart of CBIFD algorithm.

Two algorithms could be recognized [9].

**Algorithm 1.** Topology basic functions learning algorithm

*Input.* Samples of train images.

*Output.* Response matrix  $W$  and its corresponding basic functions  $A$ .

**Algorithm 2.** Fault area detection algorithm

*Input.* A normal image and its corresponding fault image.

*Output.* The contents expressed in the neurons which respond strongly.

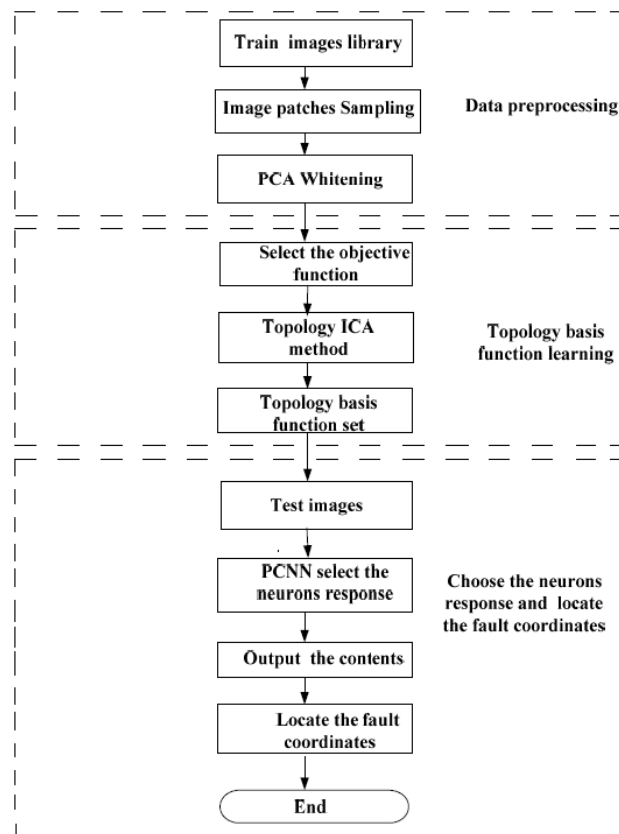

Fig. 4. The flowchart of CBIFD algorithm

After the perception, a fault detection of normal and fault images are being carried out [9]. First, the content expressed in the fault region neurons is found out, then the fault area according to the image coordinate representation method is determined and finally the fault area in a practical train fault image is detected. The result is shown in Figs 5 and 6.

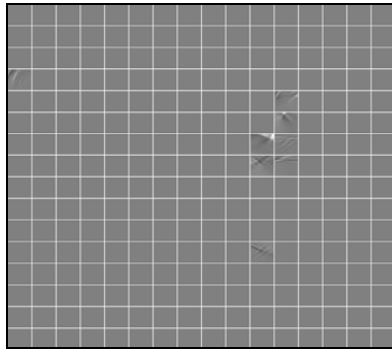

Fig. 5. Fault perception result

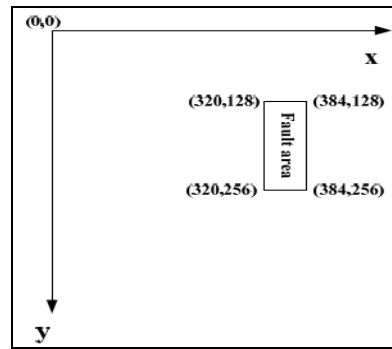

Fig. 6. Fault area location

Passive thermography by its nature is scanning the thermal radiation from the surface of the object of research with an infrared camera. It supplies information about the surface temperature of the object in thermal balance [11, 16].

In active thermography the object is in an unbalanced thermal state; the transitional temperature field ensures information about the thermophysical properties, the defects and the heterogeneous structures inside the object. The source of thermal influence may be in face or from the back side of the surface [12-15]. The measurements are performed with an infrared thermal camera. The active approach in infrared thermography is used for materials or for systems that do not supply significant difference in the temperature of the investigated surfaces.

Infrared thermography has been used in steel industry for a number of years. In metallurgy its application is for steel ladles, steel ingots, steel bar cooling bed, induction heating and quenching, bar saw cut ends, steel “cut-off” saw blades, production equipment rolls, induction heating, railroad bearing temperature test, etc.

The use of infrared imaging is very important in steel industry. One of these uses can be beneficial to the melt shop by viewing full ladles of molten steel. Once the scrap metal is melted in a melt furnace, the molten steel is poured into a large (100-ton) ladle for transfer to the next operation. It is at this point, that the exterior of the ladle is scanned with an infrared camera. A ladle of hot molten steel (1600°C) can go in a number of directions in the plant. When infrared, the exterior shell of the ladle can be scanned for possible “hot spots”. If the interior of the ladle, or brick lining, is worn or cracked, the molten steel can penetrate to the outside shell and burn through. This could be disastrous to nearby personnel and equipment. By detecting these “hot spots” early in the process, accidents can be avoided.

According to [17], in the next Figs 7-12 photographic and thermographic images of two metallurgical steel ladles are presented. These are real objects from a metallurgical plant.



Fig. 7. Photographic image of the metallurgical steel ladle 1

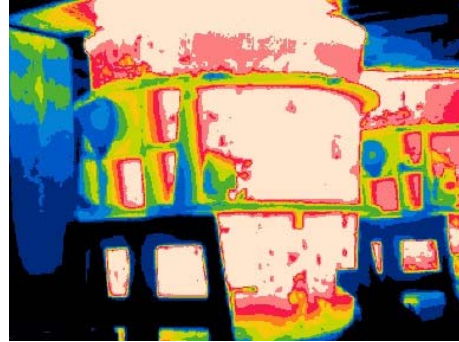

Fig. 8. Thermography image of the metallurgical steel ladle 1



Fig. 9. Photographic image of the metallurgical steel ladle 1

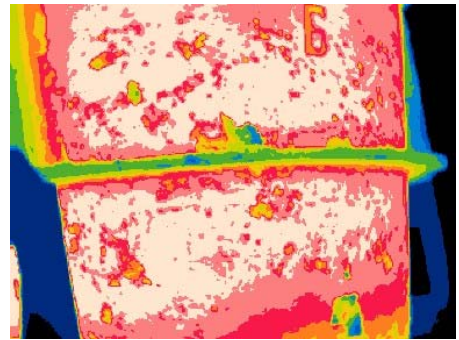

Fig. 10. Thermographic image of the metallurgical steel ladle 1



Fig. 11. Photographic image of the metallurgical steel ladle 2

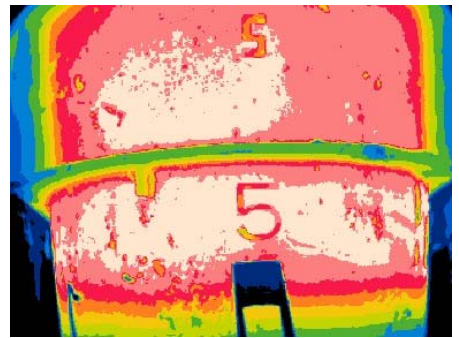

Fig. 12. Thermographic image of the metallurgical steel ladle 2

In order to depict the advantages of thermographic images application for technical diagnostic, on the following Figs 13-20 images of the bottoms of metallurgical ladles with different wearing out degree are presented.





Fig. 13. Metallurgical steel ladle 1

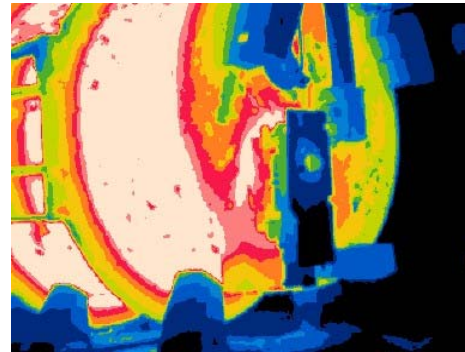

Fig. 14. Metallurgical steel ladle 1



Fig. 15. Metallurgical steel ladle 2

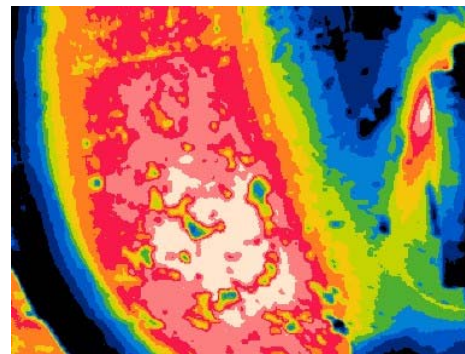

Fig. 16. Metallurgical steel ladle 2

The image analysis shows that the highest degree of wearing out has the metallurgical ladle shown on Figs 13-20. The level of wearing out is determined by the temperature (the higher the temperature – the higher the wearing out level). On the image it is presented by a brighter colour scheme.



Fig. 17. Metallurgical steel ladle 3

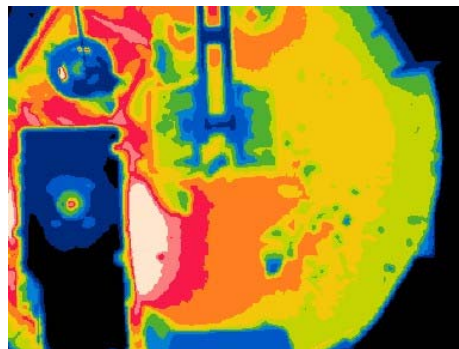

Fig. 18. Metallurgical steel ladle 3



Fig. 19. Metallurgical steel ladle 4

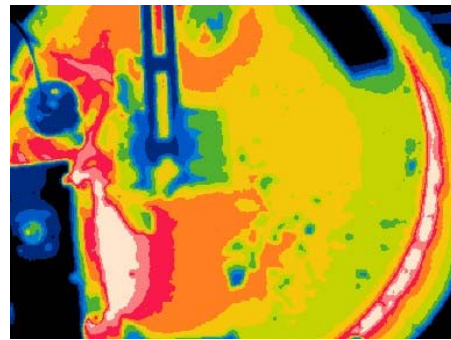

Fig. 20. Metallurgical steel ladle 4

In the majority of applications the passive thermography is used for analyses with a qualitative character rather than as a quantitative approach, because the purpose is to determine the anomalies. As a whole, these applications are based on empirical rules using expert knowledge. The transition to a quantitative analysis passes through the usage of mathematical models describing thermal characteristics of the objects used.

## 5. Conclusions

The paper presents an overview of the basic methods for image analysis. It includes examples to use techniques for image processing with regard to the purposes for technological diagnostics and predictive support of the equipment. The obvious advantage of applying modern intelligent methods for diagnostics together with the image processing techniques aiming at improving the analysis and the results from the diagnostics, are explicitly shown.

Infrared thermography is a successful diagnostic tool to estimate the current state of technological devices, installations and buildings. Timely localization of anomalies which in the majority of the cases are invisible for the human eye, avoids unplanned stays of the production due to unexpected faults thus avoiding a considerable part of expensive repairs.

**Acknowledgments:** This work has been supported by the National Science Fund, Ministry of Education, Youth and Science of Bulgaria under the Project “Intelligent Diagnostics and Decision Making in Technological Processes”, No TK-01-485/09.

## References

1. A k o v e t s k y, V. I. Deciphering Pictures. Moscow, Nedra, 1983 (in Russian).
2. A l e k s a n d r o v, V. V., N. D. G o r s k y. Image Presentation and Processing. A Recursive Approach. Moscow, Nauka, 1985 (in Russian).
3. Digital Coding TV Images. I. I. Tsukerman, Ed., Moscow, Svyaz, 1981 (in Russian).

4. K r a s i l n i k o v, N. N. Theory of Transmission and Reception of Images. Moscow, Radio and Svyaz, 1986 (in Russian).
5. J a h n e, B. Digital Image Processing. Berlin, Springer Verlag, 1991.
6. W i n s t o n, P. Artificial Intelligence. Moscow, Mir, 1980 (in Russian).
7. R o s e n f e l d, A., A. C. K a k. Digital Picture Processing. Vol. 2. Orlando, Florida, Academic Press, 1982.
8. A m a r a l, T. G., V. F. P i r e s, J. F. M a r t i n s, A. J. P i r e s, M. M. C r i s ó s t o m o. Image Processing Based Classifier for Detection and Diagnosis of Induction Motor Stator Fault. Image Processing. Yung-Sheng Chen, Ed., ISBN 978-953-307-026-1, INTECH, December 2009. 572 p.
9. P e n g - L u, Y o n g q i a n g - L i, Y u h e - T a n g, E r y a n - C h e n. Image Fault Area Detection Algorithm Based on Visual Perception, I. J. Image, Graphics and Signal Processing. Published Online February 2011 in MECS, Vol. 1, 2011, 24-30.  
<http://www.mecs-press.org/>
10. C a r l o s, A., L. A l m e i d a, W. M. C a m i n h a s, A. P. B r a g a, V. P a i v a, H. M a r t i n s, R. T o r r e s. Intelligent Detection and Diagnosis of Lightning Arresters Faults Using Digital Thermovision Image Processing Techniques, Thermosense XXVII. – In: G. Raymond Peacock, Douglas D. Burleigh, Jonathan J. Miles, Eds. Proc. of SPIE, Vol. 5782 (SPIE, Bellingham, WA, 2005).
11. H a i n, M., J. B a r t l, V. J a c k o. Active Infrared Thermography in Non-Destructive Testing. – In: Measurement'2009, 7th International Conference on Measurement, Bratislava, Institute of Measurement Science SAS, 2009, 339-343.
12. I b a r r a - C a s t a n e d o, D. G o n z a l e z, X. M a l d a g u e. Automatic Algorithm for Quantitative Pulsed Phase Thermography Calculations. – In: 16th WCNDT'2004 – World Conference on NDT, Montreal, Canada, 2004, TS4.18.5: 1-10.
13. I b a r r a - C a s t a n e d o, C., A. B e n d a d a, X. M a l d a g u e. Thermographic Image Processing for NDT, IV Conferencia Panamericana de END, Buenos Aires, October 2007.
14. M i n k i n a, W., S. D u d z i k. Infrared Thermography: Errors and Uncertainties. John Wiley & Sons, 2009.
15. Infrared Thermography. Field Application Guide. EPRI. 1999.
16. K u r i t a, K., M. O y a d o, H. T a n a k a, S. T o t t o r i. Active Infrared Thermographic Inspection Technique for Elevated Concrete Structures Using Remote Heating System, Infrared Physics & Technology, Vol. 52, 2009, 208-213.
17. B o s h n a k o v, K., V. P e t k o v, L. D o u k o v s k a, D. B o r i s s o v a, S. K o j n o v. Approaches for Diagnostic and Predictive Maintenance, SPS in Photonics Applications in Astronomy, Communications, Industry, and High-Energy Physics Experiments. – In: Proc. of SPIE, Bellingham, WA, USA, Vol. 8008, Article CID Number 80081Z, ISSN 0277-786X, ISBN 9780819472358, 2011, doi:10.1117/12.905182.