

DOI: 10.1515/adms-2016-0018

D. Fydrych*, A. Świerczyńska, G. Rogalski, J. Łabanowski

*Gdańsk University of Technology, Faculty of Mechanical Engineering, Department of Materials Science and Welding Engineering, 11/12 Narutowicza, 80-233 Gdańsk, Poland
darfydry@pg.gda.pl

TEMPER BEAD WELDING OF S420G2+M STEEL IN WATER ENVIRONMENT

ABSTRACT

The article presents the idea of the use of Temper Bead Welding (TBW) technique to improve the weldability of high strength steel at underwater wet welding conditions. Wet welding method with the use of covered electrodes is described. This work shows results of metallographic examinations and hardness measurements of samples of S420G2+M steel with weld beads performed under water. It has been shown that Temper Bead Welding technique may provide a way to reduce the hardness of the welds, thus is a useful method for improving weldability of high strength steel welded in underwater conditions. The optimum overlap of weld beads (pitch) was set of $55\div 100\%$.

Keywords: *underwater welding, wet welding, temper bead welding, weldability, high strength steel*

INTRODUCTION

Underwater parts of offshore and hydro-technical and ocean constructions often require repair works using welding technology. Most general classification of underwater welding processes divide them into dry, wet and local dry cavity ones [1-4]. A characteristic feature of most commonly used wet welding is direct underwater contact of diver-welder, electrode and base material. Among wet welding methods, the manual metal arc welding (MMA) and flux-cored arc welding (FCAW) are most often used [5-10]. Water as welding environment causes a lot of problems with the quality of obtained joints and their mechanical properties. Transferring the welding process to water environment results in: increasing cooling rate, increasing diffusible hydrogen content in deposited metal, formation of residual stresses and worse arc stability [11-15].

For these reasons, the weldability of steel in water environment is limited primarily by susceptibility to cold cracking [16-19]. In wet welding conditions possibilities of controlling the thermal cycle and reducing the formation of cracks (preheat or post-weld heat treatment)

are limited. Research is being conducted on the use of preheating by induction method, however, it has not found yet widespread use [20]. One of the ways to reduce the tendency to the formation of cold cracks having practical application is Temper Bead Welding (TBW) technique [1, 21-24].

In the TBW a reduction of post-welding residual stresses as well as a decrease of hardness in heat affected zone (HAZ) can be achieved. The technique is applied to thick sections, i.e. where it is not possible to perform heat treatment operation after welding. It consists in overlaying successive beads onto weld, that introduces local heat treatment in the area of prior made weld layer. In HAZ of the layer structural transformations may occur in the temperature range higher than A_{C1} temperature. ASME rules require to make six layers and for three first layers increased value of heat input is often used. In the case of implementation of TBW technique for preventing from formation of cold cracking it is important to determine a time interval between instants of overlaying a tempered bead and tempering one. Depending on a type of applied electrode the time up to crack forming at wet welding may reach from 3 min to 2 hours [1,24,25]. Successive parameters important from the point of view of effectiveness of the process are: value of heat input in every bead as well as distance between beads axes (pitch).

Previous experience in underwater welding suggests that the increase in number of beads has a positive effect on the impact strength of joints, which explains tempering action of next beads [1]. Furthermore, studies [21] have shown that the use of the TBW with pitch of 40% reduced the maximum hardness of the S355J2G3 steel HAZ below 350 HV.

The application of underwater welding processes covers mainly the renovation and repair works of hydro-technical structures operating in harsh marine environments [1,21,26]. Severe requirements resulting from such conditions require the use of fine-grained, high strength steels. One of the types of steel used in offshore structures is the thermo-mechanical treated S420G2+M steel. Thermo-mechanical processing of steel provides high strength properties and still provides good ductility and weldability [21,27]. Weldability of such steel in the air environment is assessed as good. In the case of underwater welding it is necessary to keep rigorous technological regime, which is primarily aimed at reducing the tendency to form cold cracks in the welds [21,28]. Due to the growing need to conduct repair works of hydro-technical facilities and subsea pipelines it is necessary to carry out research on weldability of high strength steels in the water environment [21,29].

The aim of this study was to evaluate the usefulness of TBW technique to improve the weldability of high strength structural steel S420G2+M under the wet welding conditions using MMA method. In addition, research was planned to allow determination of the most advantageous size of intra-bead pitch. The scope of work included: implementation of test welds in underwater conditions, metallographic macroscopic and microscopic examination and hardness measurements of the samples.

EXPERIMENTAL

For the tests 12 mm plate of S420G2+M steel was used. Its chemical composition and mechanical properties are given in Table 1 and 2. The carbon equivalent (CE_{IIW}) was defined according to formula (1).

$$CE_{IIW} = C + \frac{Mn}{6} + \frac{(Cu + Ni)}{15} + \frac{(Cr + Mo + V)}{5} \quad (1)$$

Table 1. Chemical composition of S420G2+M steel, wt %

C	Si	Mn	P	S	Cr	Ni	Cu	Al	CE _{IIW}
0.10	0.44	1.57	0.012	0.009	0.02	0.07	0.018	0.04	0.37

Table 2. Mechanical properties of S420G2+M steel

Yield point R _e [MPa]	Tensile strength R _m [MPa]	Elongation A [%]
480	570	30.9

The test welds were made by using Lincoln Electric OMNIA (E 42 0RC 11) electrodes of 4 mm diameter. They are general application rutile electrodes for welding in all positions, of the chemical composition: C – 0.07%, Mn – 0.5%, Si – 0.5% and the mechanical properties: R_e – min. 420 MPa, R_m – 500-640 MPa, A – min. 20%.

Samples were prepared on the special stand designed for welding at small depths (down to 50 cm) equipped in the welding power source ESAB Aristo 400 (Fig. 1).

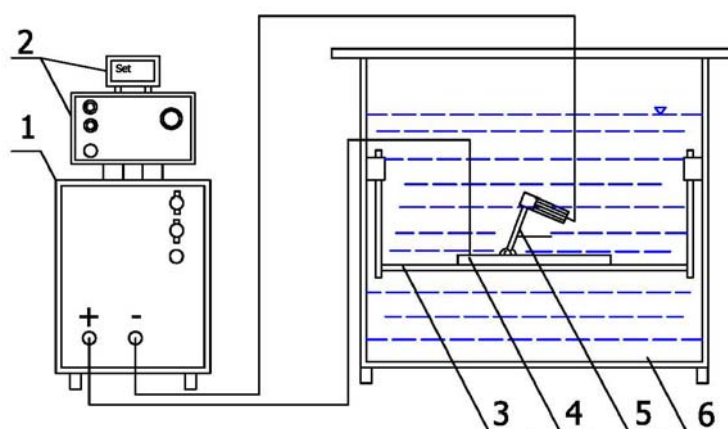

Fig. 1. Test stand for underwater wet welding: 1) welding power source, 2) control panel, 3) table, 4) plate, 5) electrode, 6) tank

Weld beads were made on 100 × 200 mm sections in the flat position with DC- polarity in accordance with the methodology used in the work [25]. Two welds were laid in non parallel direction for obtaining different distances between beads axes (pitch). The method of making welds and extracting samples for testing is shown in Fig. 2. The welding process was carried out underwater at a depth of 150 mm. The time between the implementation of two successive beads was 120 s. Applied welding parameters are summarized in Table 3. The second bead was made with a higher amount of heat input in order to increase the efficiency of thermal effect on the base bead.

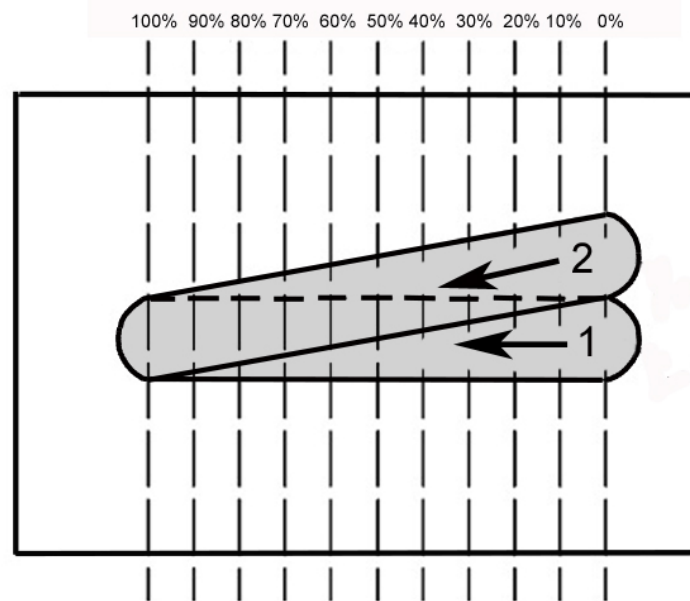

Fig. 2. The method of making test welds with an indication of cutting lines of test samples

Table 3. Applied welding parameters

Bead	Welding current [A]	Arc voltage [V]	Travel speed [mm/min]	Heat input [kJ/mm]
1	210	34.1	207	2.0
2	242	41.1	216	2.8

Metallographic examinations

Macroscopic metallographic examinations were performed in accordance with the PN-EN ISO 17639:2013-12 standard guidelines. The main objective of the research was to evaluate the percentage of overlapping of the second weld bead on the first one (pitch). The test samples were cut perpendicular to the axis of the first weld bead. Seven samples were obtained with pitch in the range of 15 to 100% and was marked with consecutive numbers 1-7. The samples were grounded and polished in accordance with standard procedure and etched with the use of Nital reagent. Examples of cross-sections of weld beads are shown in Fig. 3.

Microscopic metallographic examination were performed on etched samples with the use of LEICA MEF4M optical microscope. Fig. 4 shows the location of the areas where the microscopic observations were made.

a)



b)



c)



Fig. 3. Cross sections of weld beads: a) sample 5 - pitch 55%, b) sample 6 - pitch 89%, c) sample 7 - pitch 100%

Fig. 5 shows microstructure of the base material, weld and HAZ. Steel S420G2+M shows a fine grained ferritic-pearlitic structure with distinct banding. The microstructure of welds consists of ferrite grains in a columnar arrangement with the outline of Widmanstätten structure. In the overheating area of HAZ acicular hardening microstructure is visible. Normalization HAZ area exhibits fine-grained ferritic-pearlitic structure. There were no cold cracks in the welds and HAZs.

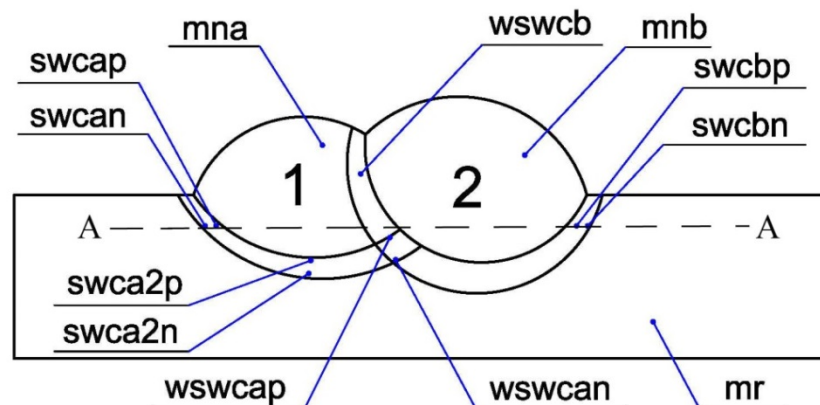

Fig. 4. Location and designation of tested areas: mr – base material, mna – 1st padding weld, mnb – 2nd padding weld, swca – HAZ of 1st padding weld, swcb – HAZ of 2nd padding weld, wswca – area of overlapping swca and swcb, wswcb – area of swcb overlapping mna, swcan, swcbrn – normalization area of swca and swcb, swcap, swcbp – overheated area of swca and swcb, A-A – hardness measurement line

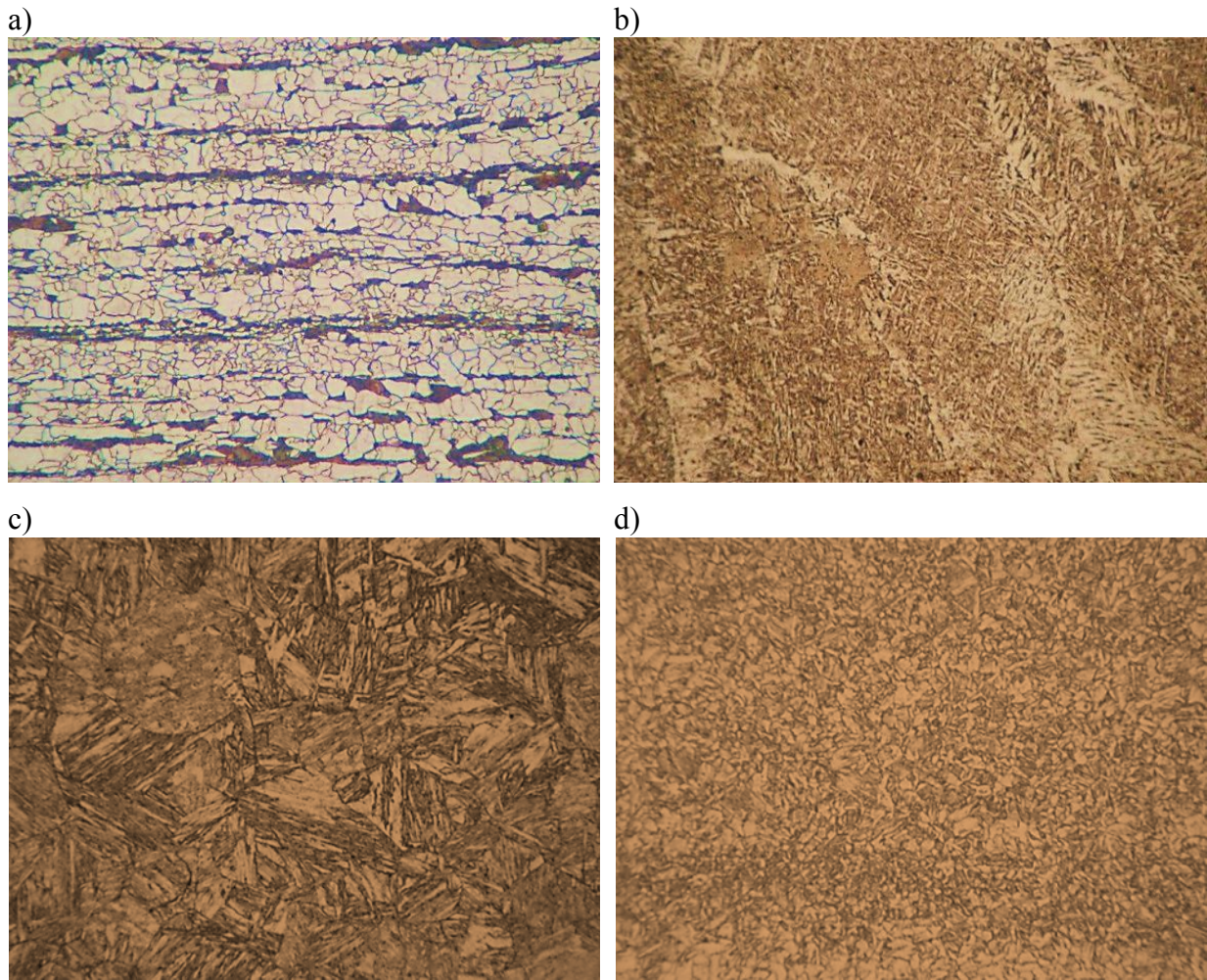

Fig. 5. Microstructures of S420G2+M steel and welded area. a) base material, b) weld, c) HAZ – overheating area d) HAZ – normalization area. Magn. 200x

Hardness measurements

Hardness measurements were made using a Vickers method with a load of 98 N (HV10) in accordance to PN-EN 9015 standard. Hardness distributions through the welds are shown in Figs. 6 - 12.

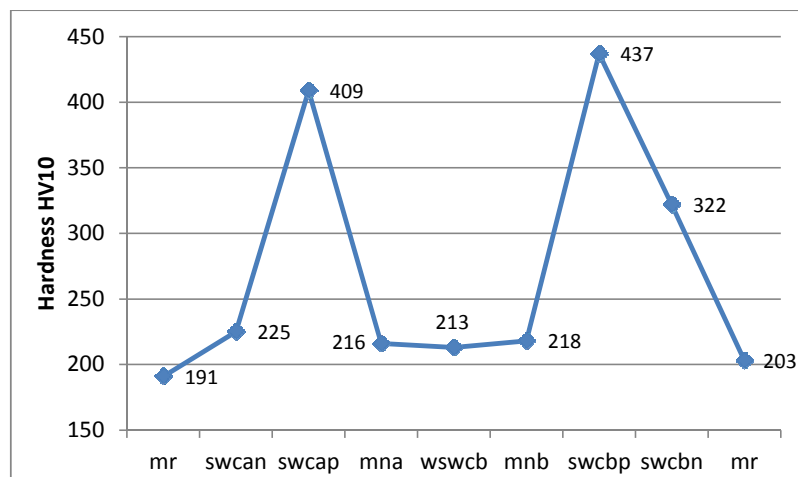

Fig. 6. Hardness distribution across sample 1 welded underwater, pitch = 15%, $HV_{max}=437$

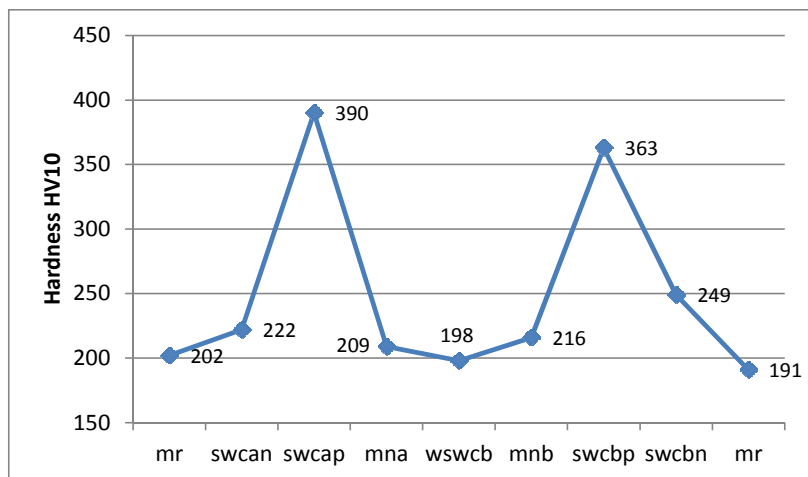

Fig. 7. Hardness distribution across sample 2 welded underwater, pitch=27%, $HV_{max}=390$

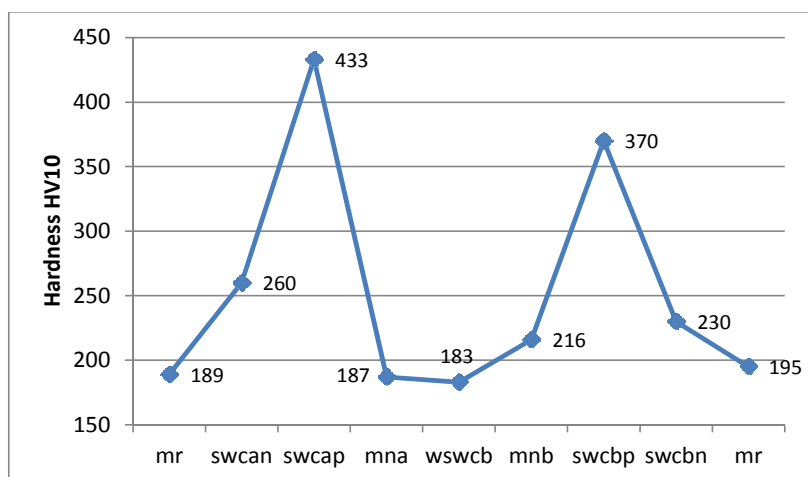

Fig. 8. Hardness distribution across sample 3 welded underwater, pitch=41%, $HV_{max}=433$

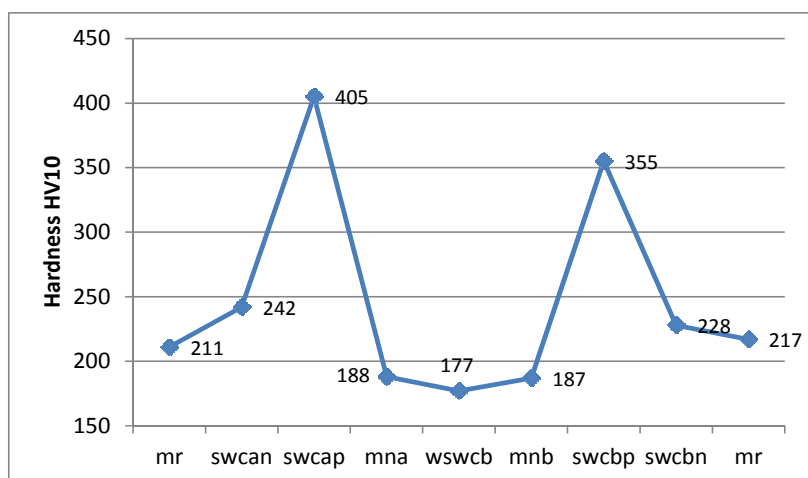

Fig. 9. Hardness distribution across sample 4 welded underwater, pitch=46%, $HV_{max}=405$

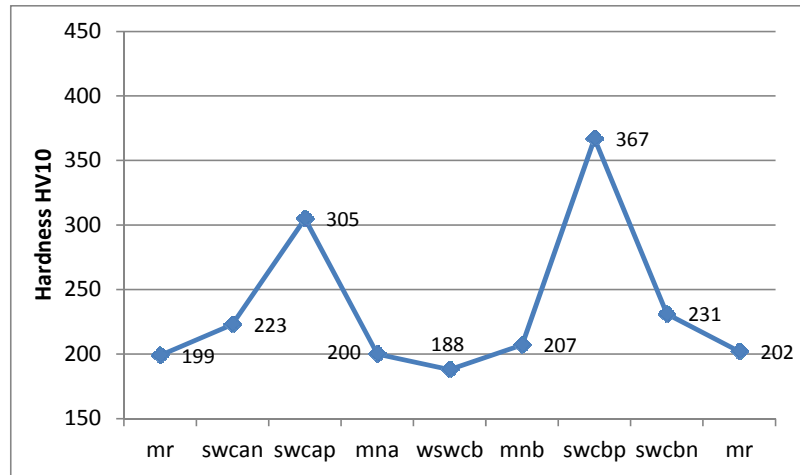

Fig. 10. Hardness distribution across sample 5 welded underwater, pitch=55%, $HV_{max}=367$

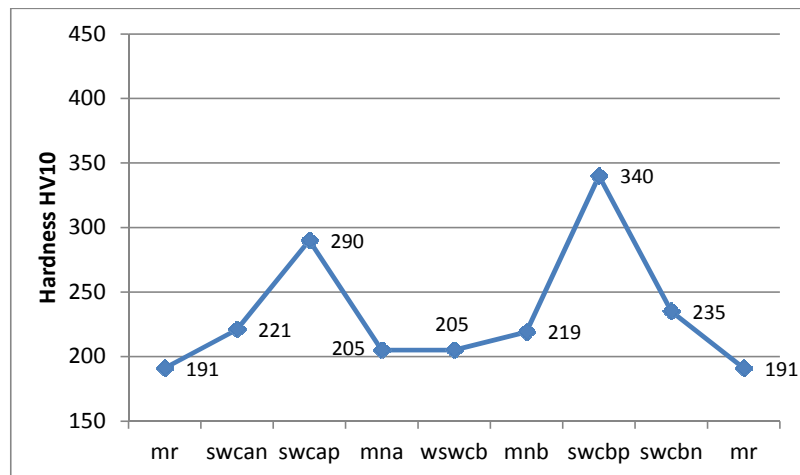

Fig. 11. Hardness distribution across sample 6 welded underwater, pitch=89%, $HV_{max}=340$

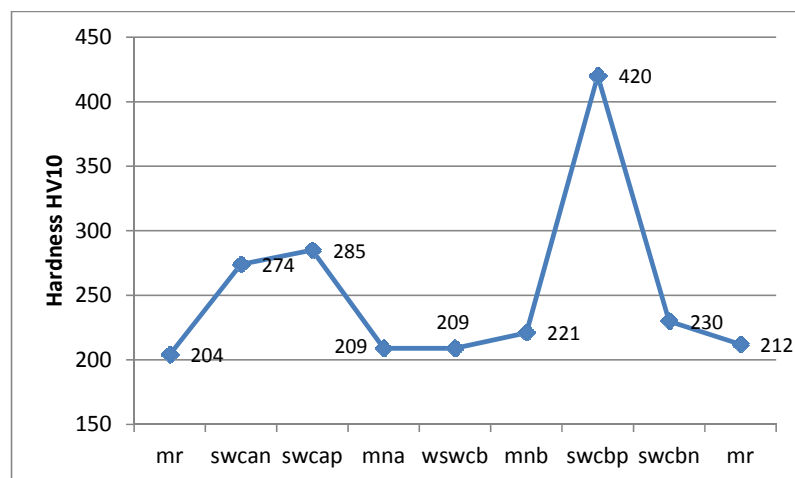

Fig. 12. Hardness distribution across sample 7 welded underwater, pitch=100%, $HV_{max}=420$

Hardness acceptance criterion for tested welds was assumed on the basis of the document Offshore Standard DNV-OS-C401 (Fabrication and testing of offshore structures) as maximum 350 HV10. HAZ hardness value exceeding 350 HV10 was found for samples with pitch less than 46%. Samples with higher overlap (pitch greater than 55%) showed decreased hardness in HAZ - below 350 HV10. Fig. 13 shows hardness in two specific HAZ areas, (normalization and overheating) of the first bead (tempered) as a function of pitch between beads.

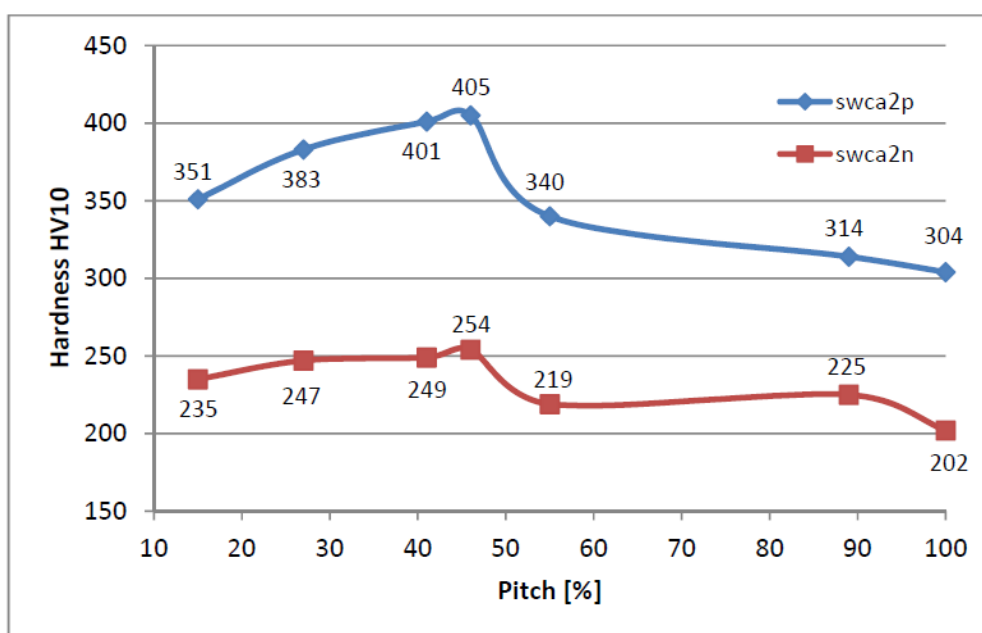

Fig. 13. Hardness distribution at areas swca2n and swca2p (Fig. 4) of the first (tempered) bead for 7 tested samples with different pitch values

DISCUSSION

Evaluation of the possibility of applying Temper Bead Welding technique to increase plasticity the HAZ area and reduce susceptibility to cold cracking of S420G2+M steel joints was performed. Research has shown that HAZ areas subjected to the influence of heat originated from temper bead showed significant reduction in hardness. It was determined that the preferable, from the viewpoint of the weldability of the steel, value of the pitch between subsequent beads is in the range of 55 to 100%.

TBW technique allows to obtain welded joints that meet the requirements of the standards specifications and regulations of Ship Classification Societies using relatively simple technological processes. This technique seems to be very beneficial when applied to underwater pipeline repairs. A limitation of this technique may be the need to maintain proper technological regime and to ensure repeatability of the process, which is particularly difficult in the case of welding in the water environment. Effectiveness of the temper bead welds also depends on many other factors including: welding position, welding parameters, arc length and angle of inclination of the electrode. Further studies should take into account these variables. This allow to determine the preferred conditions for the application of TBW technique during underwater welding.

CONCLUSIONS

- Application of Temper Bead Welding technique can be an effective method to improve the weldability of high strength steels, such as S420G2+M, in the wet welding conditions using MMA welding method.
- The effect of heat originated from temper beads reduced the HAZ maximum hardness below the critical value of 350 HV10.
- It was determined that the most preferred, from the viewpoint of weldability, range of the pitch value between subsequent beads is 55 to 100%.
- Subsequent studies should be continued towards the use of Temper Bead Welding technique to make butt and fillet welds.

REFERENCES

1. Rowe M., Liu S., Recent developments in underwater wet welding. *Science and Technology of Welding and Joining*. 6(6) (2001), 387-396.
2. Rogalski G., Łabanowski J., Fydrych D., Tomków J., Bead-on-plate welding on S235JR steel by underwater local dry chamber process. *Polish Maritime Research*. 21(2) (2014), 58-64.
3. Fydrych D., Świerczyńska A., Rogalski G., Effect of underwater wet welding conditions on the diffusible hydrogen content in deposited metal. *Metallurgia Italiana*. 11/12 (2015), 47-52.
4. Di X., Ji S., Cheng F., Wang D., Cao J.: Effect of cooling rate on microstructure, inclusions and mechanical properties of weld metal in simulated local dry underwater welding. *Materials & Design*. 88 (2015), 505-513.
5. Zhang Y., Jia C., Zhao B., Hu J., Wu C., Heat input and metal transfer influences on the weld geometry and microstructure during underwater wet FCAW. *Journal of Materials Processing Technology*. 238 (2016), 373-382.
6. Guo N., Xing X., Zhao H., Tan C., Feng J., Deng Z., Effect of water depth on weld quality and welding process in underwater fiber laser welding. *Materials & Design*. 115 (2017), 112-120.
7. Li H.L., Liu D., Yan Y.T., Guo N., Feng J.C.: Microstructural characteristics and mechanical properties of underwater wet flux-cored wire welded 316L stainless steel joints. *Journal of Materials Processing Technology*. 238 (2016), 423-430.
8. Pan J., Yang L., Hu S., Chai S., Numerical analysis of thermal cycle characteristics and prediction of microstructure in multi-pass UWW. *The International Journal of Advanced Manufacturing Technology*. 84(5-8) (2016), 1095-1102.
9. Kralj S., Garašić I., Kožuh Z.: Diffusible hydrogen in underwater wet welding. *Welding in the World*. 52 (2008), 687-692.
10. Jia C., Zhang T., Maksimov S.Y., Yuan X., Spectroscopic analysis of the arc plasma of underwater wet flux-cored arc welding. *Journal of Materials Processing Technology*. 213(8) (2013), 1370-1377.
11. Fydrych D., Łabanowski J., An experimental study of high-hydrogen welding processes. *Revista de Metalurgia*. 51(4) (2015), 5-6.

12. Arias A.R., Bracarense A.Q., Velocidade de propagação de trinca por fadiga de soldas subaquáticas molhadas: avaliação fora da água. *Soldagem & Inspeção*. 20(4) (2015), 403-411.
13. Sun Q.J., Cheng W.Q., Liu Y.B., Wang J.F., Cai C.W., Feng J.C., Microstructure and mechanical properties of ultrasonic assisted underwater wet welding joints. *Materials & Design*. 103 (2016), 63-70.
14. Gao W., Wang D., Cheng F., Deng C., Liu Y., Xu W., Enhancement of the fatigue strength of underwater wet welds by grinding and ultrasonic impact treatment. *Journal of Materials Processing Technology*. 223 (2015), 305-312.
15. Gutiérrez P.H., Rodríguez, F.C., Mondragón J.J.R., Dávila J.L.A., Mata M.P.G., Chavez C.A.G., Thermo-mechanic and microstructural analysis of an underwater welding joint. *Soldagem & Inspeção*. 21(2) (2016), 156-164.
16. Padhy G.K., Ramasubbu V., Parvathavarthini N., Wu C.S., Albert S.K., Influence of temperature and alloying on the apparent diffusivity of hydrogen in high strength steel. *International Journal of Hydrogen Energy*. 40(20) (2015), 6714-6725.
17. Nowacki J., Sajek A., Matkowski P., The influence of welding heat input on the microstructure of joints of S1100QL steel in one-pass welding. *Archives of Civil and Mechanical Engineering*. 16(4) (2016), 777-783.
18. Pandey C., Saini N., Mahapatra M.M., Kumar P., Hydrogen induced cold cracking of creep resistant ferritic P91 steel for different diffusible hydrogen levels in deposited metal. *International Journal of Hydrogen Energy*. 41(39) 2016, 17695-17712.
19. Silva L.F., Dos Santos V.R., Paciornik S., Mertens J.C.E., Chawla N., Multiscale 3D characterization of discontinuities in underwater wet welds. *Materials Characterization*. 107 (2015), 358-366.
20. Zhang H.T., Dai X.Y., Feng J.C., Hu L.L., Preliminary investigation on real-time induction heating-assisted underwater wet welding. *Welding Journal*. 1 (2015), 8-15.
21. Fydrych D., Łabanowski J., Rogalski G., Weldability of high strength steels in wet welding conditions. *Polish Maritime Research*. 20(2) (2013), 67-73.
22. de Albuquerque V.H., Silva C.C., Moura C.R., Aguiar W.M., Farias J.P., Effect of nonmetallic inclusion and banding on the success of the two-layer temper bead welding technique. *Materials & Design*. 30(4) (2009), 1068-1074.
23. Aloraier A.S., Joshi S., Price J.W., Alawadhi K.H., Hardness, microstructure, and residual stresses in low carbon steel welding with post-weld heat treatment and temper bead welding. *Metallurgical and Materials Transactions A*. 45(4) (2014), 2030-2037.
24. Aloraier A., Al-Mazrouee A., Price J.W.H., Shehata T., Weld repair practices without post weld heat treatment for ferritic alloys and their consequences on residual stresses: A review. *International Journal of Pressure Vessels and Piping*. 87(4) (2010), 127-133.
25. Aloraier A., Ibrahim R., Thomson P., FCAW process to avoid the use of post weld heat treatment. *International Journal of Pressure Vessels and Piping*. 83(5) (2006), 394-398.
26. Łabanowski J., Prokop-Strzelczyńska K., Rogalski G., Fydrych D., The effect of wet underwater welding on cold cracking susceptibility of duplex stainless steel. *Advances in Materials Science*. 16(2) (2016), 68.
27. Górka J., Study of structural changes in S700MC steel thermomechanically treated under the influence of simulated welding thermal cycles. *Indian Journal of Engineering and Materials Sciences*. 22 (2015), 497-502.

28. Kurji R., Lavigne O., Ghomashchi R., Micromechanical characterisation of weld metal susceptibility to hydrogen-assisted cold cracking using instrumented indentation. *Welding in the World*. 60(5) (2016), 883–897.
29. Sharp J. V., Billingham J., Robinson M. J., The risk management of high-strength steels in jack-ups in seawater. *Marine Structures*. 14(4) (2001), 537-551.